

UnderFloorSox[™] products are designed to transfer and disperse airflow within a raised access floor. Standard lengths and custom fittings are specifically designed to fit within a 24x24 grid of floor support pedestals.

Equipment required for installation includes:

- Drill/Driver and Self Tapping Screws (to secure inlet belts)
- Cable Cutters (1/8" Cable)

Your UFSox shipment includes the following components:

- Inlet Collar
- Straight Non-Vented Sections (2 ft, 4 ft, 6 ft, 8 ft, 10 ft, 20 ft)
- Radius Elbow (Right, Left)
- Dispersion Section (Right, Left, Both)
- Operable Endcap

Step

1

PREPARE INLET CONNECTION:

UFSox connect to a rigid metal round or oval collar. To ensure proper fit, systems are slightly oversized. For best results, configure metal duct to align with floor support structure as shown.

UFSox systems are often sized slightly larger than the clear opening height. In these cases, an oval inlet may be preferred.

DuctBelt and screws through the Anchor Patches (supplied by others) ensure a secure connection.

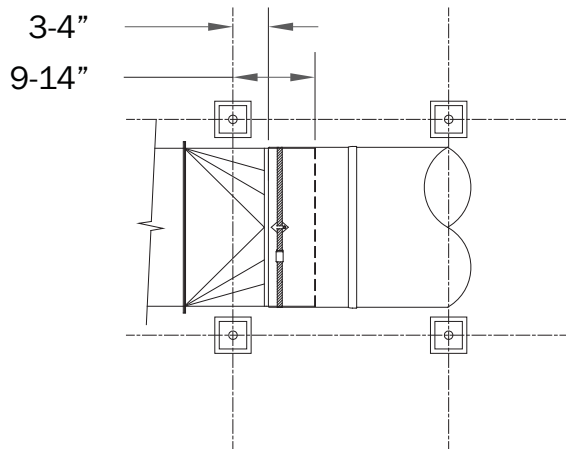

Supply options include a fixed wall plenum (shown) or direct duct connection. If start location (3-4") is not possible and runs include elbows, contact our factory for a special length alignment coupler.

Alternative inlet connection shown utilizing a rectangular to oval inlet connection. As shown, this alternative offsets the inlet connection requiring a 1 ft offset connection to ensure the standard fittings align with the floor grid.



Step



PLACE UFSOX:

From inlet collar, assemble sections of fabric as detailed in floor plan. Each section is labeled with diameter, length, and other pertinent product data. UFSOX align centered between the floor supports off the inlet connection through radius elbows.

If installing in a retrofit, ensure fabric is installed above electrical conduit.

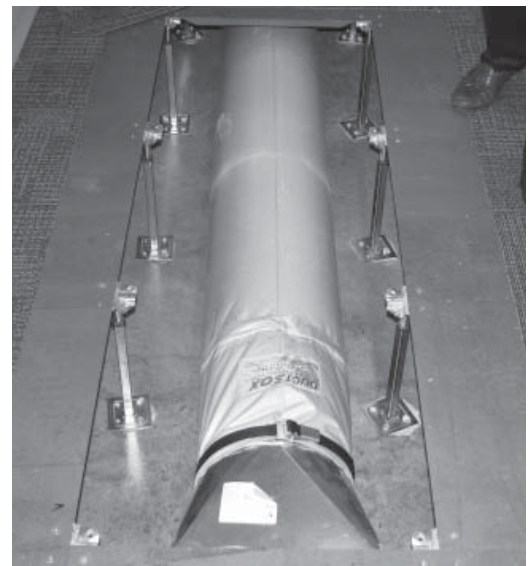

UFSOX dispersion sections are 20 ft long sections that include vents on one or both sides. For proper installation, confirm the dispersion direction matches the plan.

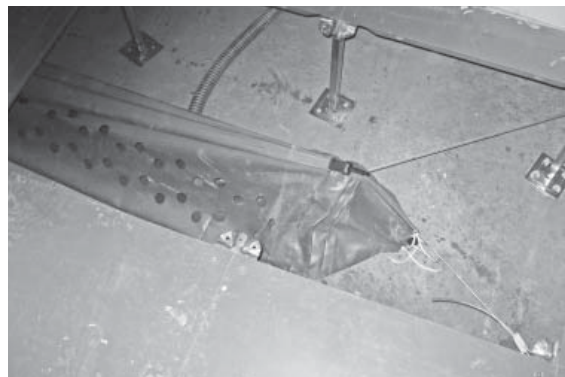

Step

3

ANCHORING:

UFSox are tethered to the floor support structure using simple tension cable. Secure locations near elbows and endcaps only. Cable snap clips are sewn on the end of each straight section and on the outlet of each radius elbow for proper anchoring.

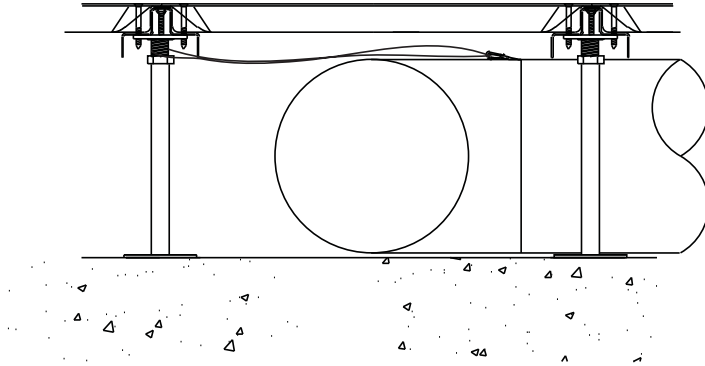

UFSox are anchored to the floor support structure using simple tension cable. Each lateral run, often including multiple pieces, shall be anchored on one or both ends. Cable snap clips are sewn on the end of each straight section and on the outlet of each radius elbow for proper anchoring.

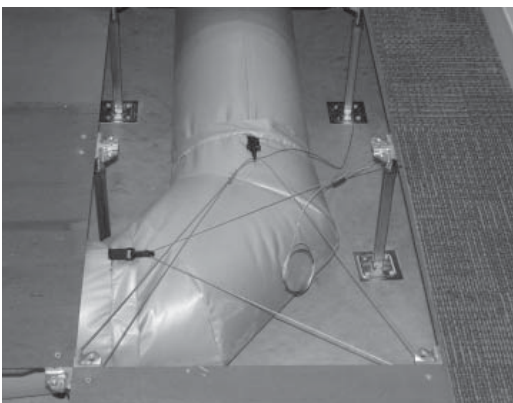
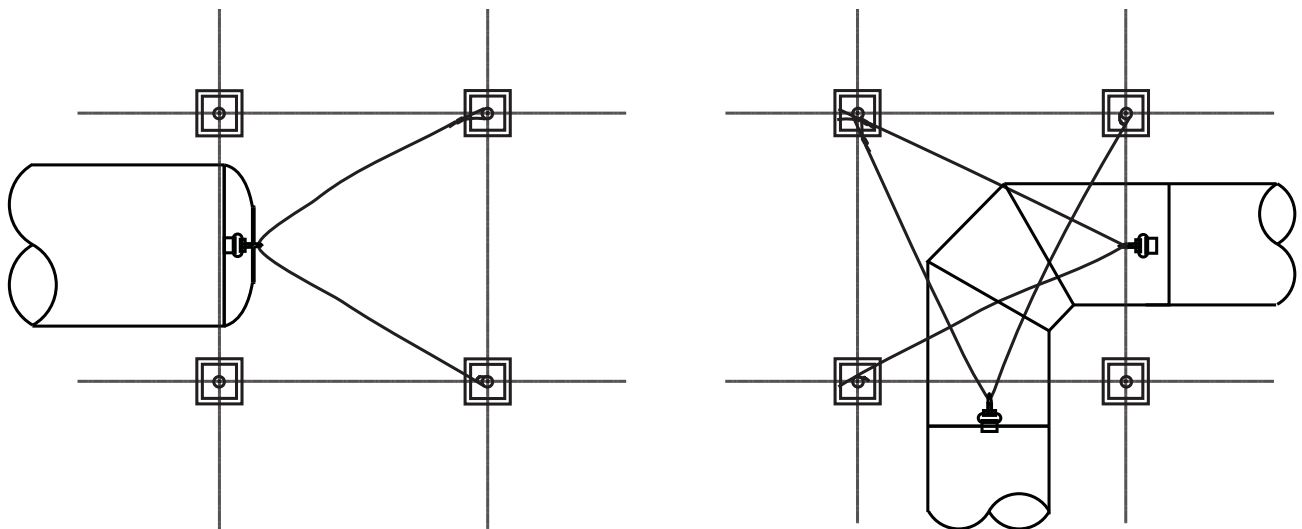

Draw tension on the fabric starting with:

- The section from the inlet, then
- Secure start of the second section (snap on outlet end of elbow), then
- Secure end of next section.

Step

4

OPERABLE ENDCAP:

The operable endcap is attached from the factory. Unless otherwise indicated. This should remain closed.

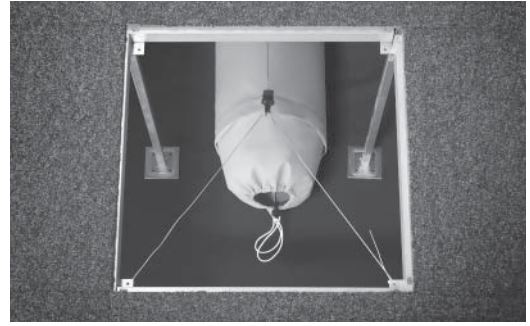

SCHEDULING:

UFSox systems anchor to the floor support structure. To preserve cleanliness, it is best to install the fabric systems with the floor support systems.

BALANCING/COMMISSIONING:

To convey and disperse airflow, UFSox require an inlet static pressure of 0.1–0.3" w.g. static pressure. The static pressure is relative to the volume of airflow plus length and number of fittings included in each individual run.

Commissioning of the equipment shall include validation airflow being dispersed through sections as specified.

MAINTENANCE:

If UFSox system becomes soiled during construction and requires cleaning, sections may be disassembled and laundered. A local commercial launderer is commonly the best resource as they are equipped with large equipment to easily clean multiple sections.

DUCTSOX[®]
Fabric Air Dispersion Products

4343 Chavenelle Road ■ Dubuque, IA 52002

Ph: 866-382-8769 ■ Fax: 563-589-2754

www.ductsox.com

© 2009 DuctSox Corp.

DSUF10309A